

 **FLXT**[®]
**PEX-AL-PEX
PIPE & FITTINGS**



Undoubtedly shelter is the man's most urgent need after food and clothes, and that's why construction researches are among the oldest and the most complicated ones which made by men. At a glance, one can see that in the big cities, most of the capital investments are allocated for construction and making buildings. Engineers and architects have made great efforts to make high quality buildings out of high quality materials with longer life-time and more reliability. The accessing to five layers FLXT® PEX-AL-PEX pipe technology is one of the greatest achievements in the field.

The most significant specification of FLXT® products is its five layers structure.

Using the latest technology and composing metal with polymer, we get the advantages of metal and polymer pipes and, at the same time, discard their malfunctions.



Internal Pressure
(Hydrostatic Stress Performance Diagram)

Comparative Stress in bar is valid for Pipe Dimension 16 x 2 mm

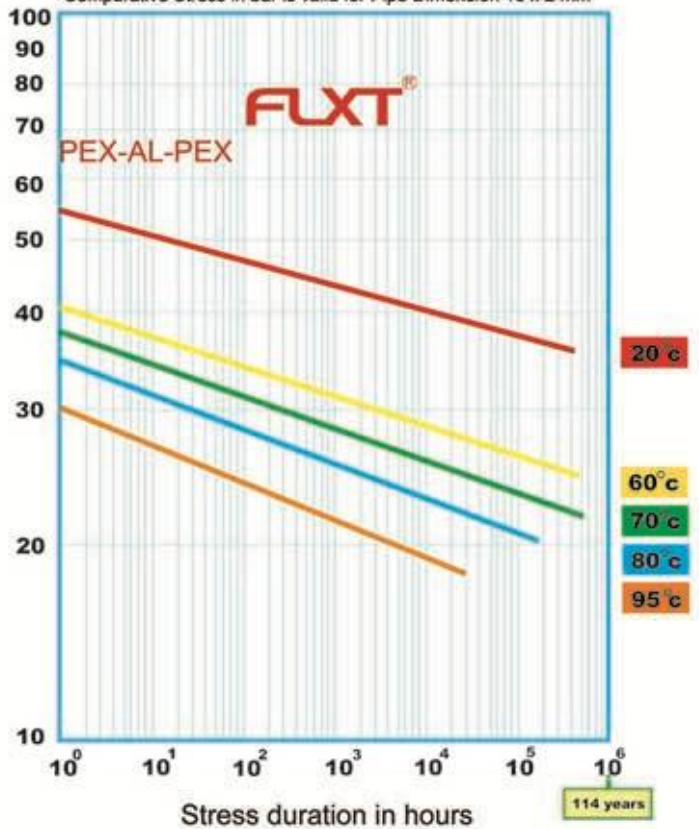

PEX polymer is applied in the inner and outer layers of the FLXT® PEX-AL-PEX pipes and it resists against corrosion, sedimentation, decay, low pressure drop, etc . Aluminum alloy with the longitudinal ultrasonic welding which is used in FLXT® PEX-AL-PEX pipes also adds the properties of oxygen penetration prevention and low longitudinal expansion coefficient in this type of product and has increased its resistance against internal and external pressure, that presents a product with high superiority compared with other products. This technology and such combination of aluminum alloy and PEX polymer offer the types of pipes with an operating temperature of 95 degrees .centigrade bearing the pressure of 10 bars

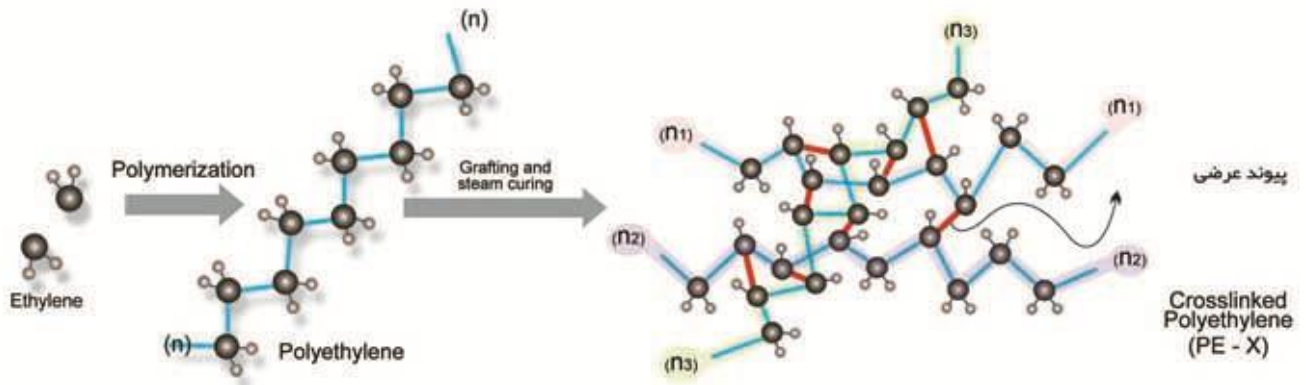

FLXT®
(PEX-AL-PEX)

| FLXT® (PEX-AL-PEX) | Polymer | Metal | |
|-----------------------|---------|-------|---|
| No | No | Yes | Corrosion of inner and outer layers |
| No | No | Yes | Sedimentation |
| Yes | No | Yes | High temperature and pressure endurance |
| Low | High | Low | Longitudinal expansion coefficient |
| No | Yes | No | Oxygen permeability |
| Yes | No | No | Ductility |
| Light | Light | Heavy | Weight |
| High | High | Low | Speed of installation |

PE is a common thermoplastic material with distinctive specifications such as electrical insulation, film-ability property and chemical resistance. It should be noted that this type of polymer has few disadvantages such as low resistance against solvent at high temperatures and tensile cracking (in the case that it contacts with liquid). To solve these problems, scientists have applied crosslinking operations in several complex chemical processes. These operations increase the resistance of pipes against high pressure and high temperature conditions as well as their chemical resistance. So PEX pipes have a high thermal resistance. Other advantages of this Polymer are as follows:

- High mechanical resistance against pressure and cracking even to - 40 degrees centigrade
- Low sound transfer coefficient
- Resistance against sedimentation and erosion
- High flexibility.

PEX-AL-PEX pipes are the only pipes certified by National Construction Rules for hot water at temperature of 95 degrees centigrade. These kinds of pipe are manufactured according to the ASTM F-1281 Standard is used for the following applications :

- Applications in **water supplying and potable water**: FLXT® productions are completely reliable for transferring potable water, whether hot or cold.
- Applications in **heating and refrigerating Systems**: it is used in air-conditioners, cold storage rooms and cold air generating systems.
- Applications in **radiant floor heating systems**: It improves human thermal comfort and saves energy about 40 percents.
- Applications in Medical and Health Industries: These pipes are used in medical industries such as transferring medical gases, dialysis systems and so on . These pipes are also used in food industries, pharmaceutical and chemical industries in which the temperature is below 100 degrees centigrade.
- Industrial Applications: It is used in chemical production plant -ship and automobile industries and the like.

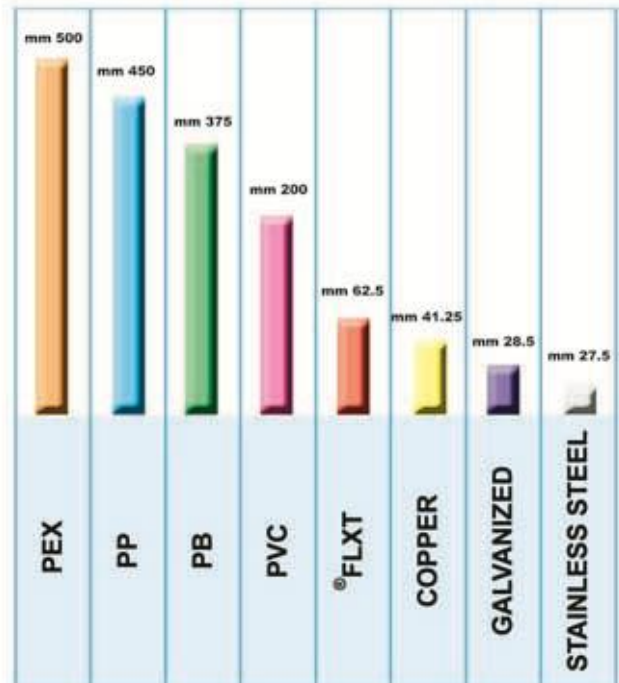

In the floor heating system, hot water flows in five-layers pipes embedded under the floor of building. The hot water energy transfers through the floor toward the surface and in the floor surface; this energy transfers upward to the room by radiation as a heat transfer process. As illustrated in the diagram, this method has the best heat distribution and is widely used in European countries for saving energy, uniform heat distribution, and avoids problems such as the carbon black on walls, blockage, wearing in the pipes, and high maintenance costs in the radiator system. In addition to heating the buildings, this system is also used for melting snow and ice in the airport runways and cargoes loading harbors, sport fields (such as football field), entrances of big buildings and hospitals, etc.

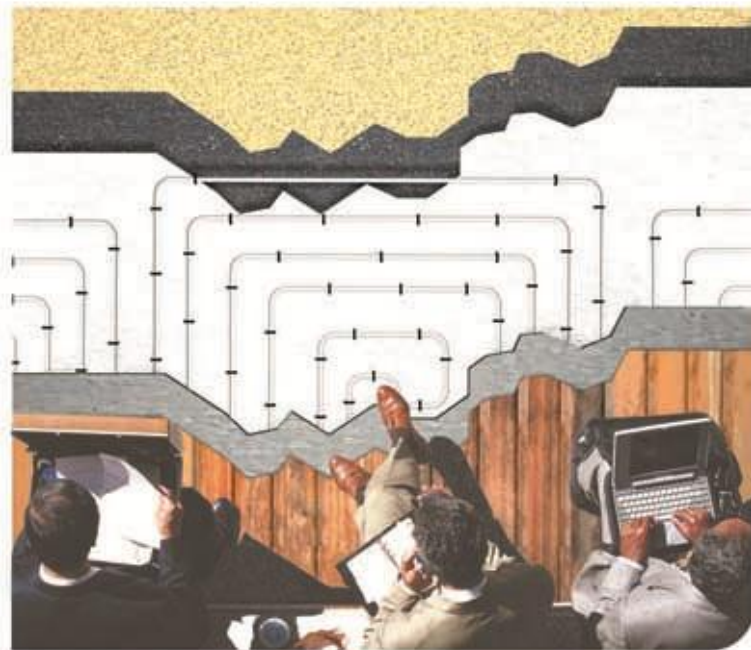
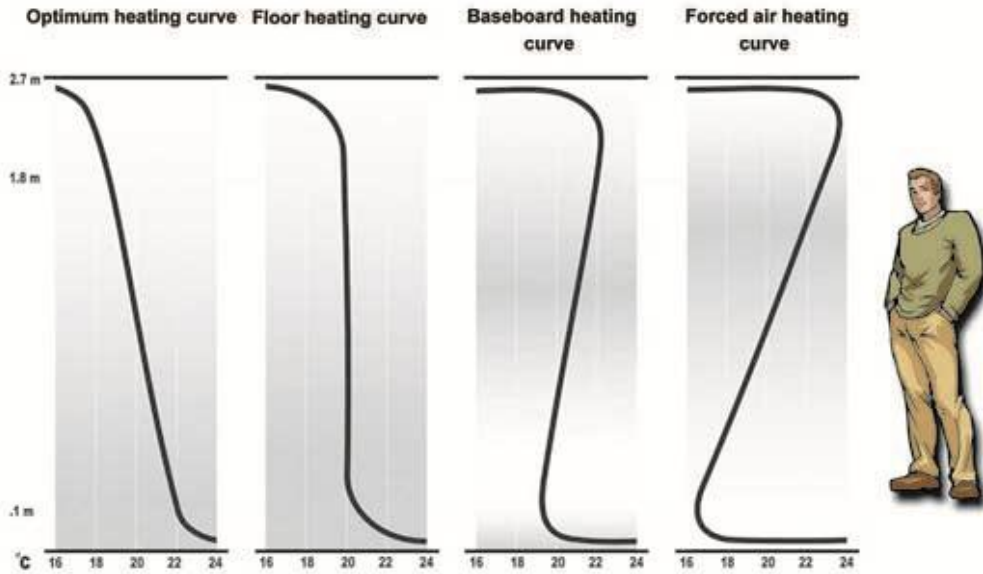

PEX-AL-PEX Pipe

| Code | Size | Pcs/Pack | Pcs/Carton |
|-----------|------|----------|------------|
| 21 100 10 | 16mm | 300 | |
| 21 100 12 | 20mm | 200 | |
| 21 100 14 | 25mm | 120 | |
| 21 100 16 | 32mm | 80 | |
| 21 100 18 | 40mm | 5 | |
| 21 100 20 | 50mm | 5 | |
| 21 100 22 | 63mm | 5 | |



PERT-AL-PERT Pipe

| Code | Size | Pcs/Pack | Pcs/Carton |
|-----------|------|----------|------------|
| 21 110 10 | 16mm | 300 | |
| 21 110 12 | 20mm | 200 | |
| 21 110 14 | 25mm | 120 | |
| 21 110 16 | 32mm | 80 | |



PE-AL-PE Pipe

| Code | Size | Pcs/Pack | Pcs/Carton |
|-----------|------|----------|------------|
| 21 120 10 | 16mm | 300 | |
| 21 120 12 | 20mm | 200 | |
| 21 120 14 | 25mm | 120 | |
| 21 120 16 | 32mm | 80 | |



Press Socket

| Code | Size | Pcs/Pack | Pcs/Carton |
|-----------|-------|----------|------------|
| 21 210 10 | 16X16 | 30 | 240 |
| 21 210 12 | 20X20 | 20 | 160 |
| 21 210 14 | 25X25 | 8 | 64 |
| 21 210 16 | 32X32 | 8 | 64 |
| 21 210 18 | 40X40 | 2 | 20 |
| 21 210 20 | 50X50 | 2 | 10 |
| 21 210 22 | 63X63 | 1 | 5 |



Press Reducing Socket

| Code | Size | Pcs/Pack | Pcs/Carton |
|-----------|-------|----------|------------|
| 21 211 10 | 20X16 | 20 | 160 |
| 21 211 12 | 25X16 | 12 | 96 |
| 21 211 14 | 25X20 | 12 | 96 |
| 21 211 18 | 32X20 | 8 | 64 |
| 21 211 20 | 32X25 | 8 | 64 |
| 21 211 24 | 40X25 | 2 | 20 |
| 21 211 26 | 40X32 | 2 | 20 |
| 21 211 30 | 50X32 | 2 | 10 |
| 21 211 32 | 50X40 | 2 | 10 |
| 21 211 36 | 63X40 | 2 | 4 |
| 21 211 38 | 63X50 | 2 | 4 |



Press Connection MT

| Code | Size | Pcs/Pack | Pcs/Carton |
|-----------|-----------|----------|------------|
| 21 212 10 | 16X1/2" | 30 | 240 |
| 21 212 14 | 20X1/2" | 20 | 160 |
| 21 212 16 | 20X3/4" | 10 | 80 |
| 21 212 18 | 20X1" | 10 | 80 |
| 21 212 22 | 25X3/4" | 10 | 80 |
| 21 212 24 | 25X1" | 10 | 80 |
| 21 212 28 | 32X1" | 10 | 80 |
| 21 212 30 | 32X1 1/4" | 6 | 48 |
| 21 212 32 | 40X1 1/4" | 2 | 20 |
| 21 212 38 | 50X1 1/2" | 2 | 10 |
| 21 212 42 | 63X2" | 1 | 5 |



Products

Press Connection FT

| Code | Size | Pcs/Pack | Pcs/Carton |
|-----------|-----------|----------|------------|
| 21 213 10 | 16x1/2" | 30 | 240 |
| 21 213 14 | 20x1/2" | 20 | 160 |
| 21 213 16 | 20x3/4" | 10 | 80 |
| 21 213 18 | 20x1" | 10 | 80 |
| 21 213 22 | 25x3/4" | 8 | 64 |
| 21 213 24 | 25x1" | 8 | 64 |
| 21 213 28 | 32x1" | 6 | 48 |
| 21 213 30 | 32x1 1/4" | 2 | 20 |
| 21 213 34 | 40x1 1/2" | 2 | 20 |
| 21 213 38 | 50x1 1/2" | 1 | 5 |
| 21 213 42 | 63x2" | 10 | 80 |



Press Elbow 90°

| Code | Size | Pcs/Pack | Pcs/Carton |
|-----------|-------|----------|------------|
| 21 220 10 | 16X16 | 24 | 192 |
| 21 220 12 | 20X20 | 14 | 112 |
| 21 220 14 | 25X25 | 8 | 64 |
| 21 220 16 | 32X32 | 4 | 32 |
| 21 220 18 | 40X40 | 1 | 10 |
| 21 220 20 | 50X50 | 1 | 10 |
| 21 220 22 | 63X63 | 1 | 2 |



Press Elbow 45°

| Code | Size | Pcs/Pack | Pcs/Carton |
|-----------|-------|----------|------------|
| 21 221 18 | 40X40 | 1 | 10 |
| 21 221 20 | 50X50 | 1 | 10 |
| 21 221 22 | 60X60 | | |



Press Elbow 90° MT

| Code | Size | Pcs/Pack | Pcs/Carton |
|-----------|---------|----------|------------|
| 21 222 10 | 16x1/2" | 20 | 160 |
| 21 222 16 | 20x3/4" | 10 | 80 |
| 21 222 22 | 25x3/4" | 8 | 64 |
| 21 222 28 | 32x1" | 4 | 32 |



Press Elbow 90° FT

| Code | Size | Pcs/Pack | Pcs/Carton |
|-----------|-----------|----------|------------|
| 21 223 10 | 16x1/2" | 20 | 160 |
| 21 223 14 | 20x1/2" | 10 | 96 |
| 21 223 16 | 20x3/4" | 10 | 80 |
| 21 223 22 | 25x3/4" | 8 | 64 |
| 21 223 28 | 32x1" | 4 | 32 |
| 21 223 34 | 40x1 1/2" | 2 | 4 |
| 21 223 38 | 50x1 1/2" | 2 | 4 |



Press Wall Elbow FT

| Code | Size | Pcs/Pack | Pcs/Carton |
|-----------|---------|----------|------------|
| 21 225 10 | 16X1/2" | 10 | 80 |
| 21 225 14 | 20X1/2" | 10 | 80 |



Press Wall Tee 180° FT

| Code | Size | Pcs/Pack | Pcs/Carton |
|-----------|------------|----------|------------|
| 21 235 10 | 16X1/2"X16 | 6 | 48 |
| 21 235 14 | 20X1/2"X20 | 6 | 48 |



Press Tee

| Code | Size | Pcs/Pack | Pcs/Carton |
|-----------|----------|----------|------------|
| 21 230 10 | 16x16x16 | 16 | 128 |
| 21 230 12 | 20x20x20 | 10 | 80 |
| 21 230 14 | 25x25x25 | 4 | 32 |
| 21 230 16 | 32x32x32 | 4 | 32 |
| 21 230 18 | 40x40x40 | 1 | 10 |
| 21 230 20 | 50x50x50 | 1 | 5 |
| 21 230 22 | 63x63x63 | 1 | 2 |



Press Wall Corner Tee 90° FT

| Code | Size | Pcs/Pack | Pcs/Carton |
|-----------|------------|----------|------------|
| 21 237 10 | 16X1/2"X16 | 6 | 48 |
| 21 237 14 | 20X1/2"X20 | 4 | 32 |



Press Reducing Tee

| Code | Size | Pcs/Pack | Pcs/Carton |
|-----------|----------|----------|------------|
| 21 231 10 | 16x20x16 | 12 | 96 |
| 21 231 12 | 20x16x16 | 12 | 96 |
| 21 231 14 | 20x16x20 | 10 | 80 |
| 21 231 16 | 20x20x16 | 10 | 80 |
| 21 231 20 | 25x16x16 | 6 | 48 |
| 21 231 22 | 25x16x20 | 6 | 48 |
| 21 231 24 | 25x16x25 | 6 | 48 |
| 21 231 28 | 25x20x20 | 6 | 48 |
| 21 231 30 | 25x20x25 | 4 | 32 |
| 21 231 32 | 25x32x25 | 4 | 32 |
| 21 231 36 | 32x16x32 | 4 | 32 |
| 21 231 38 | 32x20x32 | 4 | 32 |
| 21 231 42 | 32x25x25 | 4 | 32 |
| 21 231 44 | 32x25x32 | 4 | 32 |
| 21 231 48 | 40x20x40 | 1 | 10 |
| 21 231 50 | 40x25x40 | 1 | 10 |
| 21 231 54 | 40x32x32 | 1 | 10 |
| 21 231 56 | 40x32x40 | 1 | 10 |
| 21 231 60 | 50x25x50 | 1 | 5 |
| 21 231 62 | 50x32x50 | 1 | 5 |
| 21 231 66 | 50x40x50 | 1 | 5 |
| 21 231 70 | 63x25x63 | 1 | 2 |
| 21 231 74 | 63x40x63 | 1 | 2 |



Press Wall Elbow With Flange MT

| Code | Size | Pcs/Pack | Pcs/Carton |
|-----------|---------|----------|------------|
| 21 320 12 | 16X3/4" | 6 | 48 |
| 21 320 16 | 20X3/4" | 6 | 48 |



Press Wall Elbow With Flange FT

| Code | Size | Pcs/Pack | Pcs/Carton |
|-----------|---------|----------|------------|
| 21 321 10 | 16X1/2" | 6 | 48 |
| 21 321 14 | 20X1/2" | 6 | 48 |



Press Reducer Tee FT

| Code | Size | Pcs/Pack | Pcs/Carton |
|-----------|------------|----------|------------|
| 21 233 10 | 16x1/2"x16 | 10 | 80 |
| 21 233 14 | 20x1/2"x20 | 6 | 48 |
| 21 233 16 | 20x3/4"x20 | 6 | 48 |
| 21 233 20 | 25x1/2"x25 | 4 | 32 |
| 21 233 22 | 25x3/4"x25 | 4 | 32 |
| 21 233 28 | 32x3/4"x32 | 4 | 32 |
| 21 233 34 | 40x3/4"x40 | 1 | 10 |
| 21 233 40 | 50x1"x50 | 1 | 5 |



Press Wall Corner Tee With Flange 90° FT

| Code | Size | Pcs/Pack | Pcs/Carton |
|-----------|------------|----------|------------|
| 21 331 10 | 16X1/2"X16 | 6 | 48 |
| 21 331 14 | 20X1/2"X20 | 4 | 32 |



Press Wall Tee With Flange 180° MT

| Code | Size | Pcs/Pack | Pcs/Carton |
|-----------|------------|----------|------------|
| 21 332 12 | 16X3/4"X16 | 6 | 48 |
| 21 332 16 | 20X3/4"X20 | 6 | 48 |



Cap MT

| Code | Size | Pcs/Pack | Pcs/Carton |
|-----------|--------|----------|------------|
| 21 352 10 | 3/4" | 30 | |
| 21 352 12 | 1" | 20 | |
| 21 352 14 | 1 1/4" | 15 | |



Press Wall Tee With Flange 180° FT

| Code | Size | Pcs/Pack | Pcs/Carton |
|-----------|------------|----------|------------|
| 21 333 10 | 16X1/2"X16 | 6 | 48 |
| 21 333 14 | 20X1/2"X20 | 6 | 48 |



Press Cap

| Code | Size | Pcs/Pack | Pcs/Carton |
|-----------|------|----------|------------|
| 21 410 10 | 16mm | 30 | 240 |
| 21 410 12 | 20mm | 20 | 160 |
| 21 410 14 | 25mm | 16 | 128 |
| 21 410 16 | 32mm | 8 | 64 |
| 21 410 18 | 40mm | 6 | 48 |
| 21 410 20 | 50mm | 3 | 24 |
| 21 410 22 | 63mm | 2 | 10 |



Press screw connector FT

| Code | Size | Pcs/Pack | Pcs/Carton |
|-----------|----------|----------|------------|
| 21 350 10 | 16X1/2" | 20 | 160 |
| 21 350 14 | 20X1/2" | 14 | 112 |
| 21 350 22 | 25X3/4" | 8 | 64 |
| 21 350 28 | 32X1 | 4 | 32 |
| 21 350 32 | 40X1 1/4 | 2 | 10 |
| 21 350 38 | 50X1 1/2 | 2 | 10 |



Plug

| Code | Size | Pcs/Pack | Pcs/Carton |
|-----------|------|----------|------------|
| 21 420 50 | 1/2" | 600 | |



Manifold FT

| Code | Size | Pcs/Pack | Pcs/Carton |
|-----------|----------------|----------|------------|
| 21 351 12 | (3/4"X 1/2") | 2b . | 5 |
| 21 351 13 | (3/4"X 1/2") | 3b . | 5 |
| 21 351 22 | (1" X 1/2") | 2b . | 5 |
| 21 351 23 | (1" X 1/2") | 3b . | 5 |
| 21 351 24 | (1" X 1/2") | 4b . | 5 |
| 21 351 25 | (1" X 1/2") | 5b . | 5 |
| 21 351 26 | (1" X 1/2") | 6b . | 5 |
| 21 351 28 | (1" X 1/2") | 8b . | 5 |
| 21 351 33 | (1" X 3/4") | 3b . | 5 |
| 21 351 34 | (1" X 3/4") | 4b . | 5 |
| 21 351 35 | (1" X 3/4") | 5b . | 5 |
| 21 351 46 | (1 1/4"X 1/2") | 6b . | 4 |
| 21 351 48 | (1 1/4"X 1/2") | 8b . | 4 |
| 21 351 49 | (1 1/4"X 1/2") | 9b . | 4 |
| 21 351 53 | (1 1/4"X 3/4") | 3b . | 4 |
| 21 351 54 | (1 1/4"X 3/4") | 4b . | 4 |
| 21 351 55 | (1 1/4"X 3/4") | 5b . | 4 |
| 21 351 56 | (1 1/4"X 3/4") | 6b . | 4 |



Plug

| Code | Size | Pcs/Pack | Pcs/Carton |
|-----------|------|----------|------------|
| 21 420 50 | 1/2" | 60 | |
| 21 420 62 | 3/4" | 62 | |
| 21 420 64 | 1" | 64 | |



Long Plug

| Code | Size | Pcs/Pack | Pcs/Carton |
|-----------|----------|----------|------------|
| 21 421 10 | 1/2"Blue | 100 | |
| 21 421 12 | 1/2" Red | 100 | |
| 21 421 20 | 3/4"Blue | 60 | |
| 21 421 22 | 3/4" Red | 60 | |



Mounting Plate

| Code | Size | Pcs/Pack | Pcs/Carton |
|-----------|-------|----------|------------|
| 21 430 10 | 73mm | 50 | |
| 21 430 12 | 153mm | 25 | |
| 21 430 14 | 280mm | 20 | |
| 21 430 16 | 500mm | 15 | |



O- ring

| Code | Size | Pcs/Pack | Pcs/Carton |
|-----------|------|----------|------------|
| 21 451 10 | 16mm | 100 | |
| 21 451 12 | 20mm | 100 | |
| 21 451 14 | 25mm | 100 | |
| 21 451 16 | 32mm | 100 | |
| 21 451 18 | 40mm | 50 | |
| 21 451 20 | 50mm | 50 | |
| 21 451 22 | 63mm | 50 | |
| 21 451 50 | 1/2" | 50 | |
| 21 451 52 | 3/4" | 50 | |
| 21 451 54 | 1" | 50 | |



Pipe Clamp

| Code | Size | Pcs/Pack | Pcs/Carton |
|-----------|------|----------|------------|
| 21 440 10 | 16mm | 800 | |
| 21 440 12 | 20mm | 700 | |
| 21 440 14 | 25mm | 600 | |
| 21 440 16 | 32mm | 250 | |



EPE Foam - Pipe

| Code | Size | Pcs/Pack | Pcs/Carton |
|-----------|------|----------|------------|
| 22 110 10 | 16mm | 100 | |
| 22 110 12 | 20mm | 100 | |
| 22 110 14 | 25mm | 100 | |
| 22 110 16 | 32mm | 100 | |
| 22 110 18 | 40mm | 50 | |
| 22 110 20 | 50mm | 50 | |
| 22 110 22 | 63mm | 50 | |



Double Pipe Clamp

| Code | Size | Pcs/Pack | Pcs/Carton |
|-----------|------|----------|------------|
| 21 441 10 | 16mm | 350 | |



XPE Foam - Pipe

| Code | Size | Pcs/Pack | Pcs/Carton |
|-----------|------|----------|------------|
| 22 110 10 | 16mm | 100 | |
| 22 110 12 | 20mm | 100 | |
| 22 110 14 | 25mm | 100 | |
| 22 110 16 | 32mm | 100 | |
| 22 110 18 | 40mm | 50 | |
| 22 110 20 | 50mm | 50 | |
| 22 110 22 | 63mm | 50 | |



Pipe Staple

| Code | Size | Pcs/Pack | Pcs/Carton |
|-----------|------|----------|------------|
| 21 442 10 | 16MM | | 1500 |



EPE Foam - Sheet

| Code | Size | Pcs/Pack | Pcs/Carton |
|-----------|------|----------|------------|
| 22 200 10 | 16mm | 100 | |
| 22 200 12 | 20mm | 100 | |
| 22 200 14 | 25mm | 100 | |
| 22 200 16 | 32mm | 100 | |
| 22 200 18 | 40mm | 50 | |
| 22 200 20 | 50mm | 50 | |
| 22 200 22 | 63mm | 50 | |



Stainless Steel Ring

| Code | Size | Pcs/Pack | Pcs/Carton |
|-----------|------|----------|------------|
| 21 450 10 | 16 | 100 | 800 |
| 21 450 12 | 20 | 80 | 640 |
| 21 450 14 | 25 | 30 | 240 |
| 21 450 16 | 32 | 24 | 192 |
| 21 450 18 | 40 | 10 | 80 |
| 21 450 20 | 50 | 6 | 48 |
| 21 450 22 | 63 | 2 | 16 |



XPE Foam - Sheet

| Code | Size | Pcs/Pack | Pcs/Carton |
|-----------|------|----------|------------|
| 22 210 10 | 16mm | 100 | |
| 22 210 12 | 20mm | 100 | |
| 22 210 14 | 25mm | 100 | |
| 22 210 16 | 32mm | 100 | |
| 22 210 18 | 40mm | 50 | |
| 22 210 20 | 50mm | 50 | |
| 22 210 22 | 63mm | 50 | |



Ball Valve

| Code | Size |
|-----------|------|
| 23 100 10 | 1/2" |
| 23 100 12 | 1/2" |
| 23 100 14 | 3/4" |
| 23 100 16 | 3/4" |
| 23 100 18 | 1" |
| 23 100 20 | 1" |



Bending Spring

| Code | Size | Pcs/Pack | Pcs/Carton |
|-----------|----------|----------|------------|
| 23 201 10 | 45x45 cm | | |
| 23 201 12 | 45x65 cm | 1 | |
| 23 201 14 | 45x90 cm | | |



Ball Valve

| Code | Size |
|-----------|------|
| 23 110 10 | 1/2" |
| 23 110 12 | 1/2" |
| 23 110 14 | 3/4" |
| 23 110 16 | 3/4" |
| 23 110 18 | 1" |
| 23 110 20 | 1" |



Manifold Stand

| Code | Size | Pcs/Pack | Pcs/Carton |
|-----------|------|----------|------------|
| 23 202 10 | | ... | |



Ball Valve

| Code | Size |
|-----------|------|
| 23 120 10 | 1/2" |
| 23 120 12 | 1/2" |
| 23 120 14 | 3/4" |
| 23 120 16 | 3/4" |
| 23 120 18 | 1" |
| 23 120 20 | 1" |



Clamp

| Code | Size | Pcs/Pack | Pcs/Carton |
|-----------|--------|----------|------------|
| 23 203 12 | 3/4" | | |
| 23 203 14 | 1" | | |
| 23 203 16 | 1 1/4" | | |



Auto Air Eliminator

| Code | Size |
|-----------|------|
| 23 150 14 | 1" |



Screw Connector FT

| Code | Size | Pcs/Pack | Pcs/Carton |
|-----------|---------|----------|------------|
| 23 209 10 | 16x1/2" | 60 | 240 |
| 23 209 12 | 16x3/4" | 40 | 160 |
| 23 209 14 | 20x1/2" | 30 | 240 |
| 23 209 16 | 20x3/4" | 40 | 160 |
| 23 209 20 | 25x3/4" | 20 | 80 |
| 23 209 22 | 25x1" | 12 | 48 |
| 23 209 26 | 32x1" | 6 | 24 |



By Pass Valve

| Code | Size |
|-----------|------|
| 23 155 14 | 1" |



Spare Connector

| Code | Size | Pcs/Pack | Pcs/Carton |
|-----------|---------|----------|------------|
| 23 209 50 | 16x1/2" | 50 | 400 |
| 23 209 52 | 16x3/4" | 40 | 320 |
| 23 209 54 | 20x1/2" | 40 | 320 |
| 23 209 56 | 20x3/4" | 40 | 320 |
| 23 209 60 | 25x3/4" | 30 | 240 |
| 23 209 62 | 25x1" | 30 | 240 |



Nipple MT

| Code | Size | Pcs/Pack | Pcs/Carton |
|-----------|------|----------|------------|
| 23 210 10 | 1/2" | 40 | 320 |
| 23 210 12 | 3/4" | 20 | 160 |
| 23 210 14 | 1" | 16 | 128 |



Reducer MT

| Code | Size | Pcs/Pack | Pcs/Carton |
|-----------|-----------|----------|------------|
| 23 211 10 | 1/2"x3/4" | 30 | 240 |
| 23 211 14 | 3/4"x1" | 20 | 160 |



Nipple MT +FT

| Code | Size | Pcs/Pack | Pcs/Carton |
|-----------|------|----------|------------|
| 23 212 10 | 1/2" | 30 | 240 |
| 23 212 12 | 3/4" | 20 | 160 |
| 23 212 14 | 1" | 8 | 64 |



Reducer MT+FT

| Code | Size | Pcs/Pack | Pcs/Carton |
|-----------|------------|----------|------------|
| 23 213 10 | 1/2"x 3/4" | 30 | 240 |
| 23 213 12 | 1"x 3/4" | 15 | 120 |
| 23 213 14 | 3/4"x 1" | 18 | 144 |



Elbow 90° MT

| Code | Size | Pcs/Pack | Pcs/Carton |
|-----------|------|----------|------------|
| 23 220 10 | 1/2" | 20 | 160 |
| 23 220 12 | 3/4" | 10 | 80 |



Elbow 90° MT+FT

| Code | Size | Pcs/Pack | Pcs/Carton |
|-----------|-------|----------|------------|
| 23 223 10 | 1/2" | 20 | 160 |
| 23 223 12 | 3/4" | 10 | 80 |
| 23 223 14 | 1" | 7 | 56 |
| 23 223 62 | 32x1" | 4 | 32 |



Wall Elbow FT

| Code | Size | Pcs/Pack | Pcs/Carton |
|-----------|------|----------|------------|
| 23 225 10 | 1/2" | 10 | 80 |



Tee MT

| Code | Size | Pcs/Pack | Pcs/Carton |
|-----------|------|----------|------------|
| 23 230 10 | 1/2" | 20 | 160 |
| 23 230 12 | 3/4" | 10 | 80 |
| 23 230 14 | 1" | 7 | 56 |



Reducer Tee MT

| Code | Size | Pcs/Pack | Pcs/Carton |
|-----------|--------------|----------|------------|
| 23 231 34 | 32x3/4"x32 | 3 | 24 |
| 23 231 36 | 32x3/4"x3/4" | 5 | 40 |
| 23 231 38 | 3/4"x32x3/4" | 5 | 40 |



Wall Tee FT

| Code | Size | Pcs/Pack | Pcs/Carton |
|-----------|------|----------|------------|
| 23 235 10 | 1/2" | 10 | 80 |



Wall Corner Tee FT

| Code | Size | Pcs/Pack | Pcs/Carton |
|-----------|------|----------|------------|
| 23 237 10 | 1/2" | 10 | 80 |



Wall Corner Tee With flange MT

| Code | Size | Pcs/Pack | Pcs/Carton |
|-----------|---------------|----------|------------|
| 23 332 10 | 1/2"MT+3/4"MT | 6 | 48 |



Wall Elbow With Flange MT

| Code | Size | Pcs/Pack | Pcs/Carton |
|-----------|---------------|----------|------------|
| 23 320 12 | 1/2"MT+3/4"MT | 10 | 80 |



Wall Tee With Flange FT

| Code | Size | Pcs/Pack | Pcs/Carton |
|-----------|---------------|----------|------------|
| 23 333 10 | 1/2"MT+1/2"FT | 6 | 48 |



Wall Elbow With Flange FT

| Code | Size | Pcs/Pack | Pcs/Carton |
|-----------|---------------|----------|------------|
| 23 321 10 | 1/2"MT+3/4"FT | 10 | 80 |



Cap FT

| Code | Size | Pcs/Pack | Pcs/Carton |
|-----------|------|----------|------------|
| 23 410 10 | 1/2" | 40 | 320 |
| 23 410 12 | 3/4" | 20 | 160 |
| 23 410 14 | 1" | 15 | 120 |



Wall Corner Tee With flange MT

| Code | Size | Pcs/Pack | Pcs/Carton |
|-----------|---------------|----------|------------|
| 23 330 12 | 1/2"MT+3/4"MT | 6 | 48 |



Check Valve

| Code | Size | Pcs/Pack | Pcs/Carton |
|-----------|------|----------|------------|
| 24 100 10 | 1/2" | | |
| 24 100 12 | 3/4" | | |



Wall Corner Tee With Flange FT

| Code | Size | Pcs/Pack | Pcs/Carton |
|-----------|---------------|----------|------------|
| 23 331 10 | 1/2"MT+3/4"MT | 6 | 48 |



Shutt of Valve

| Code | Size | Pcs/Pack | Pcs/Carton |
|-----------|------|----------|------------|
| 24 110 10 | 1/2" | | |
| 24 110 12 | 3/4" | | |
| 24 110 14 | 1" | | |



Network Valve

| Code | Size | Pcs/Pack | Pcs/Carton |
|-----------|------|----------|------------|
| 24 120 10 | 1/2" | | |
| 24 120 12 | 3/4" | | |
| 24 120 14 | 1" | | |



Bending Tool

| Code | Size | Pcs/Pack | Pcs/Carton |
|-----------|----------|----------|------------|
| 25 140 10 | 16-32 mm | | |



(Bending Spring(outer

| Code | Size | Pcs/Pack | Pcs/Carton |
|-----------|------|----------|------------|
| 25 101 10 | 16mm | | |
| 25 101 12 | 20mm | | |
| 25 101 14 | 25mm | | |
| 25 101 16 | 32mm | | |



Charger

| Code | Size | Pcs/Pack | Pcs/Carton |
|-----------|------|----------|------------|
| 25 151 10 | | | |



Calibrator

| Code | Size | Pcs/Pack | Pcs/Carton |
|-----------|------|----------|------------|
| 25 110 10 | 16mm | | |
| 25 110 12 | 20mm | | |
| 25 110 14 | 25mm | | |
| 25 110 16 | 32mm | | |
| 25 110 18 | 40mm | | |
| 25 110 20 | 50mm | | |
| 25 110 22 | 63mm | | |



Battery

| Code | Size | Pcs/Pack | Pcs/Carton |
|-----------|------|----------|------------|
| 25 152 10 | | | |



Pipe Cutter

| Code | Size | Pcs/Pack | Pcs/Carton |
|-----------|------|----------|------------|
| 25 120 10 | M 42 | | |



Jaw & Die

| Code | Size | Pcs/Pack | Pcs/Carton |
|-----------|------|----------|------------|
| 25 154 10 | 16 | | |
| 25 154 12 | 20 | | |
| 25 154 14 | 25 | | |
| 25 154 16 | 32 | | |



Plumbing Tool Box

| Code | Size | Pcs/Pack | Pcs/Carton |
|-----------|------|----------|------------|
| 25 130 10 | | | |



Die

| Code | Size | Pcs/Pack | Pcs/Carton |
|-----------|------|----------|------------|
| 25 155 18 | 40 | 50 | |
| 25 155 20 | 50 | 40 | |
| 25 155 22 | 63 | 40 | 40-50 |
| | | 40 | |
| | | 30 | |
| | | 30 | |



63



Jaw

| Code | Size | Pcs/Pack | Pcs/Carlon |
|-----------|-------|----------|------------|
| 25 156 18 | 40-50 | | |
| 25 156 22 | 63 | | |
| | | | 40-50 |
| | | | 63 |



Pipe decoiler

| Code | Size | Pcs/Pack | Pcs/Carlon |
|-----------|------|----------|------------|
| 25 170 10 | | | |



FLXT GmbH

Ettore - Bugatti - Str. 6 -14
51149 Cologne / Germany
Tel : +49 (0) 2203 9122 5027
Fax : +49 (0) 2203 9122 5427

WWW.FLXT.COM
info@flxt.com